

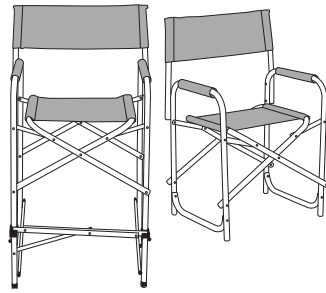

Instructions for Directors Chair



WHAT'S IN THE BOX

(1) Tall or (1) Standard Directors Chair and (1) Carry Bag

SET UP

Opening Your Tall Directors Chair

1. Remove chair from Carry Bag and place on a stable flat surface.
2. Tilt the chair slightly to one side and place both hands on the **Seat Frame**. (Fig. A)
3. Push down until the chair locks in place. (Fig. B)
4. Ensure that hinged **Footrest** is snapped into place.

Fig. A

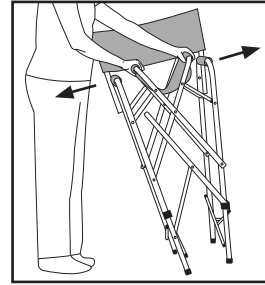
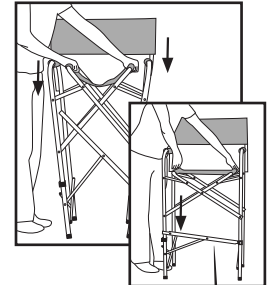

Fig. B



Closing Your Tall Directors Chair

1. Before closing your chair, disengage **Footrest**. The hinged **Footrest** must be disengaged for the chair to close properly. (Fig. C)
2. With the chair placed firmly on a flat surface, and the **Footrest** disengaged, grasp each side of the **Seat Frame**. Bracing your forearms against each armrest, lift up until chair releases.
3. Continue to lift chair by **Seat Frame** until it is folded closed. (Fig. D)
4. Store in the Carry Bag provided.

Fig. C

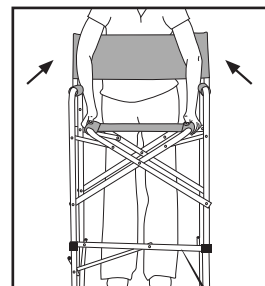
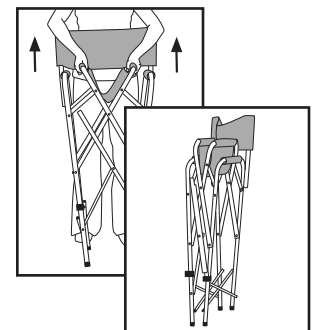

Fig. D



Opening Your Standard Directors Chair

1. Remove chair from Carry Bag and place on a stable flat surface.
2. Place both hands on each side of the **Seat Frame** (Fig. E) and push down until chair locks in place. (Fig. F)

Closing Your Standard Directors Chair

1. With the chair placed firmly on a flat surface, grasp each side of the **Seat Frame**. Bracing your forearms against each armrest, lift up until chair releases.
2. Continue to lift chair by **Seat Frame** until it is folded closed.
3. Store in the Carry Bag provided.

Fig. E

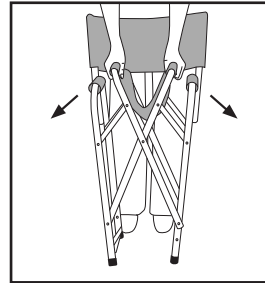
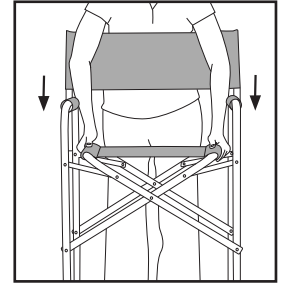

Fig. F



WARNING

- This chair holds a maximum of 225 lbs. Exceeding this limit will damage the chair and may cause personal injury.
- Care should be taken to avoid tipping while seated.
- Use chair only on level ground.
- To avoid injuries to fingers, use care when folding the chair.

CARE & MAINTENANCE

- Spot clean only with mild soap and water.
- Air dry completely before storing to avoid mildew.
- Do not bleach.

Fig. G

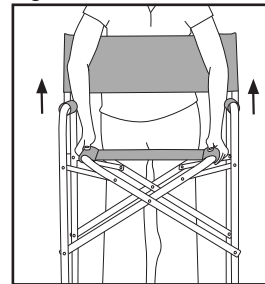

Fig. H

